

A multi-machine scaling of halo current rotation

Clayton E. Myers¹

N. W. Eidietis,² S. N. Gerasimov,³ S. P. Gerhardt,¹ R. S. Granetz,⁴
T. C. Hender,³ G. Pautasso,⁵ and JET Contributors

¹ *Princeton Plasma Physics Laboratory (NSTX-U)*

² *General Atomics (DIII-D)*

³ *Culham Centre for Fusion Energy (JET)*

⁴ *Massachusetts Institute of Technology (Alcator C-Mod)*

⁵ *Max-Planck-Institut für Plasmaphysik (ASDEX Upgrade)*



**Theory & Simulations of
Disruptions Workshop
Princeton, NJ
July 17–19, 2017**



EUROfusion JET



CCFE
CULHAM CENTRE FOR
FUSION ENERGY



**Max-Planck-Institut
für Plasmaphysik**

This work has been carried out within the framework of the EUROfusion Consortium and has received funding from the Euratom research and training programme 2014-2018 under grant agreement No 633053.

The views and opinions expressed herein do not necessarily reflect those of the European Commission.

Disruption halo currents are a major concern for reactor-scale tokamaks

- Helical halo currents are driven in the scrape-off layer (SOL)
 - Flux conservation
 - Plasma motion
- SOL currents are force-free, wall currents are not → large vessel forces
- Halo currents exhibit toroidal asymmetries
 - Kink mode due to low edge q
 - **Asymmetries often rotate toroidally**
- Intense debate about the toroidal component of the halo current in the wall contact region
 - Zakharov 2008 → ‘Hiro’ currents
 - Roccella 2016 → Asymm. eddy currents

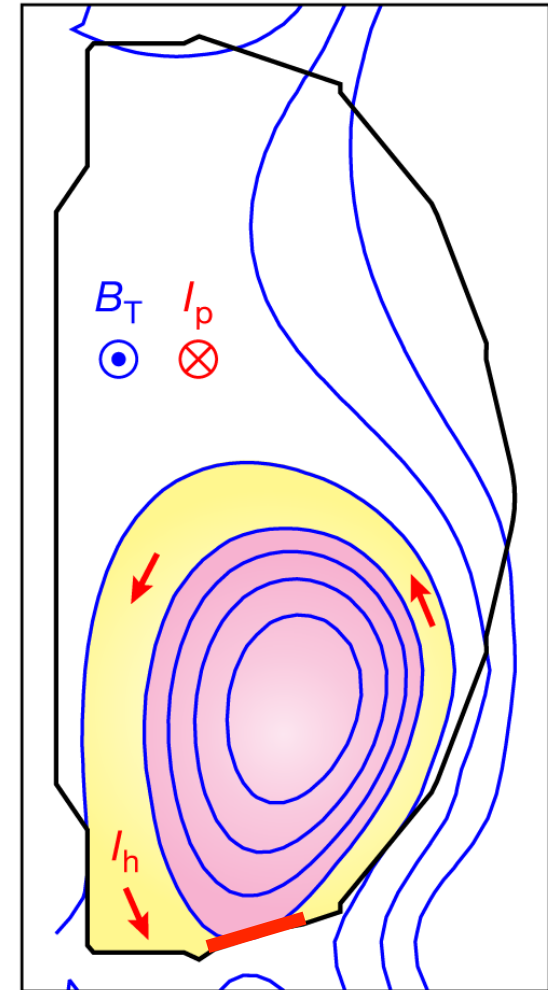

Motivation: The rotating halo current problem

- Substantial halo current rotation observed in a number of devices:
 - JET Noll 1996, Riccardo 2004 & 2009, Gerasimov 2014 & 2015
 - C-Mod Granetz et al. *Nucl. Fusion* **36**, 545 (1996)
 - DIII-D Evans et al. *J. Nucl. Mater.* **241-243**, 606 (1997)
 - AUG Pautasso et al. *Nucl. Fusion* **51**, 043010 (2011)
 - NSTX Gerhardt *Nucl. Fusion* **53**, 023005 (2013)
- The concern for ITER:
 - Forces are dynamically amplified if $N_{\text{rot}} > 2-3$
 - Critical mechanical resonances in the 3-8 Hz range [Schioler FED 2011]
 - Overall response is broader (10-20 Hz) [Bachmann FED 2011 & Lehnen]
- **Critical question:**
 - **Are halo currents generated during unmitigated disruptions in ITER likely to complete 2-3 full rotations at frequencies below 20 Hz?**

Key quantities: Rotation duration and frequency

- Are halo currents generated during unmitigated disruptions in ITER likely to complete 2-3 full rotations at frequencies below 20 Hz?
- Deconstruct N_{rot} into rotation duration and rotation frequency:

$$N_{\text{rot}} = \langle f_{\text{h}} \rangle \cdot t_{\text{rot}} = \frac{\langle v_{\text{h}} \rangle}{2\pi R} \cdot t_{\text{rot}}$$

N_{rot} = number of rotations

$\langle f_{\text{h}} \rangle$ = rotation frequency

t_{rot} = rotation duration

$\langle v_{\text{h}} \rangle$ = rotation velocity (toroidal)

R = major radius

- Construct a new ITPA halo current rotation database to develop empirical scalings for $\langle f_{\text{h}} \rangle$ and t_{rot}

Presentation outline

- The ITPA halo current rotation database
- Current quench analysis and scalings
- The halo current rotation analysis procedure
- Development of rotation scalings
 - Halo current rotation duration, t_{rot}
 - Halo current rotation frequency, $\langle f_h \rangle$
- Projection to ITER
 - Projected ITER behavior is marginal w.r.t. ITER resonances
 - $N_{\text{rot}} > 3$ at $\langle f_h \rangle > 20$ Hz is likely
 - Some rotation at $\langle f_h \rangle < 20$ Hz is also likely
 - $N_{\text{rot}} \sim 3$ at $\langle f_h \rangle \sim 9\text{--}20$ Hz is possible
- Results submitted to *Nuclear Fusion* (2017)

Halo current sensor arrays in the ITPA database

a AUG (2008-2015)

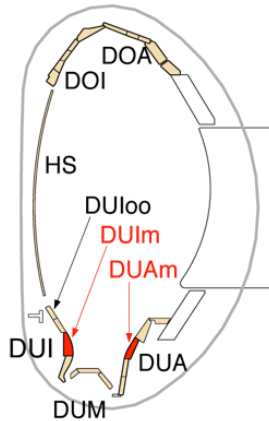

b NSTX (2010)

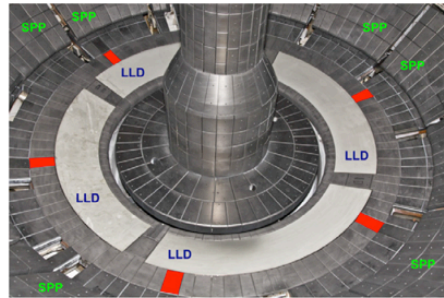

c DIII-D (1997)

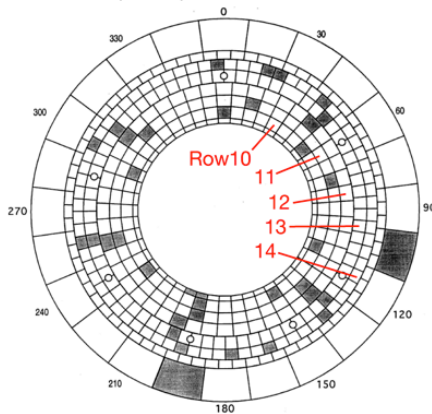

d C-Mod (1995-1996)

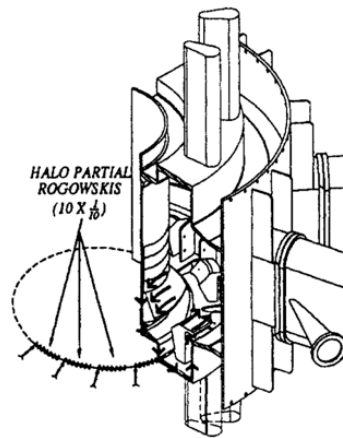

- The DIII-D, AUG, and NSTX sensors are shunt tile arrays
- The C-Mod sensors are partial toroidal rogowski coils
- In JET, poloidal field sensor arrays provide I_p asymmetry measurements

e JET (2005-2015)

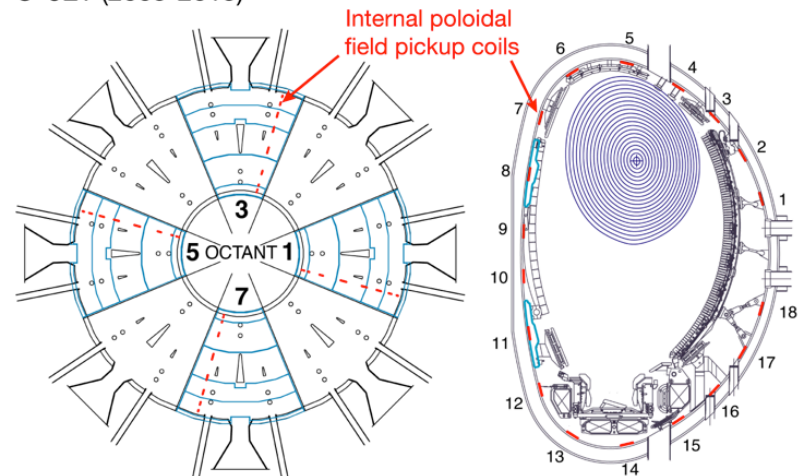

The ITPA halo current rotation database

- One 'data unit' per shot:
 - Halo current vs. toroidal angle (one or more sensor arrays)
 - At least four toroidal locations per sensor array
 - Auxiliary data (I_p , B_T , R , a , κ , S , MGI, ...)
- Contents of the database (813 total shots):

– C-Mod	Partial rogowskis	Moly	148 shots	× 1+ poloidal locations
– NSTX	Shunt tiles	Carbon	141 shots	× 1+ poloidal locations
– AUG-C	Shunt tiles	Carbon	129 shots	× 2+ poloidal locations
– AUG-W	Shunt tiles	Tungsten	49 shots	× 2+ poloidal locations
– DIII-D	Shunt tiles	Carbon	51 shots	× 4+ poloidal locations
– JET-C	I_p asymmetry	Carbon	145 shots	× 4 toroidal octants
– JET-ILW	I_p asymmetry	ITER-like	150 shots	× 4 toroidal octants
- All disruptions in the database are unmitigated

Analysis procedure: current quench

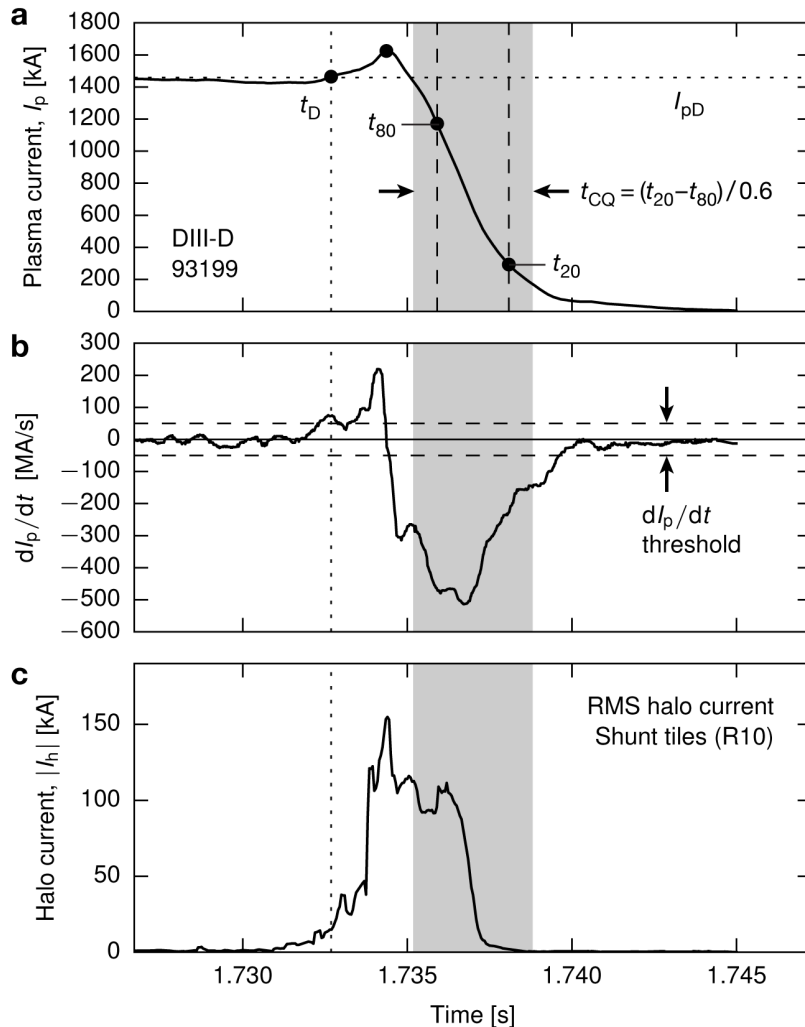

- Use standard $t_{CQ} = (t_{20} - t_{80}) / 0.6$ current quench analysis
- Disruption time, t_D , determined with a threshold on dI_p/dt
- For JET, use Gerasimov algorithm for $t_D \rightarrow$ includes loop voltage
- t_{20} and t_{80} mark when I_p/I_{pD} is 80% and 20%, respectively
- The RMS halo current, $|I_h|$, is shown for a single shunt tile array (DIII-D Row 10)

Characteristic current quench timescales

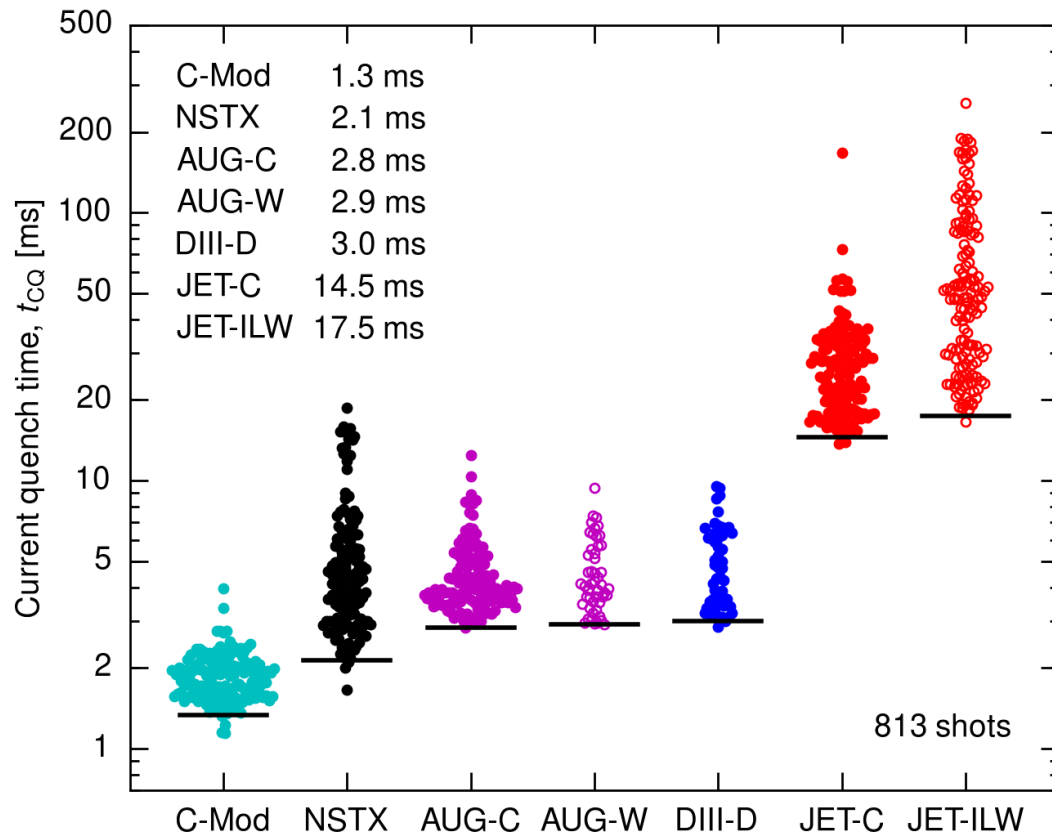

- Denote the shot-specific current quench time as t_{CQ}
- Each device has a characteristic minimum current quench time, τ_{CQ}
- Define τ_{CQ} as the fastest quench time for each machine excepting outliers
- Conclude that CQ timing for asymmetric VDEs unaffected by wall material

Combine JET-C and JET-ILW data

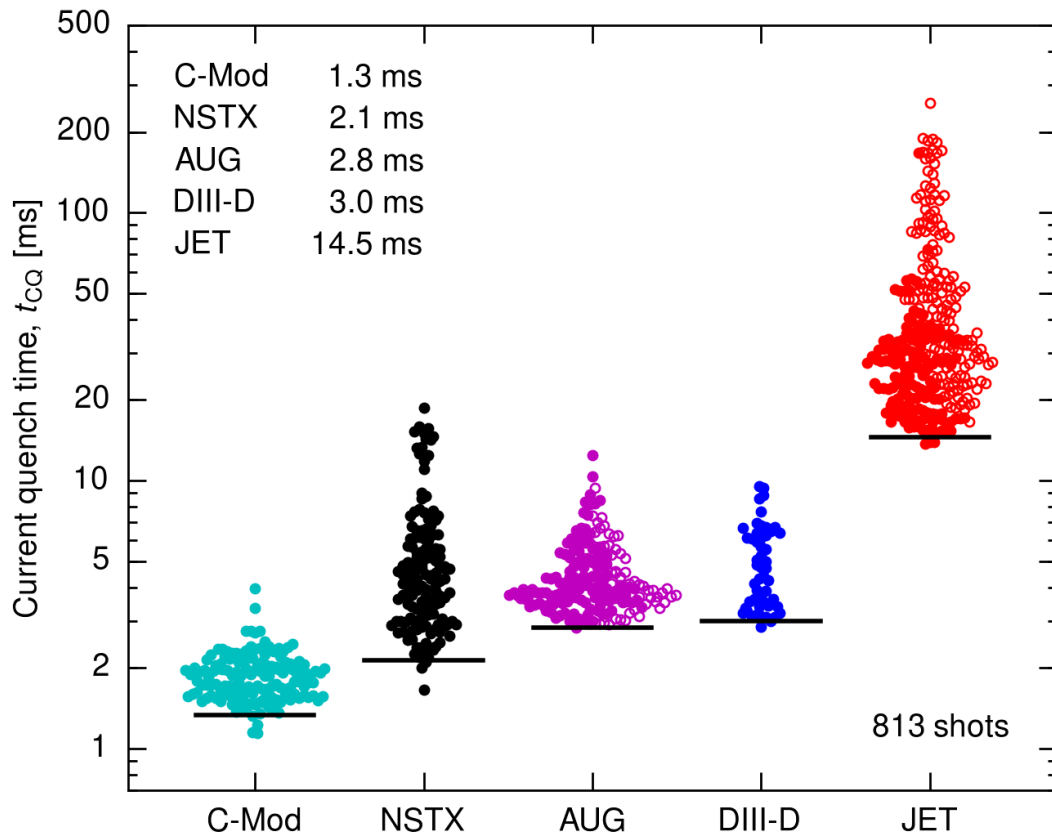

- Denote the shot-specific current quench time as t_{CQ}
- Each device has a characteristic minimum current quench time, τ_{CQ}
- Define τ_{CQ} as the fastest quench time for each machine excepting outliers
- Conclude that CQ timing for asymmetric VDEs unaffected by wall material
- Combine AUG-C, AUG-W and JET-C, JET-ILW

The Wesley $\tau_{CQ} \sim L/R$ current quench scaling

- Conjecture that the characteristic fast current quench time, τ_{CQ} , is set by the plasma L/R time:

$$\mathcal{L} = \mu_0 R \ell, \quad \text{where } \ell = \ln\left(\frac{8R}{a}\right) - 2 + \frac{\ell_i}{2}$$

$$\mathcal{R} = \eta \left(\frac{2\pi R}{S} \right), \quad \text{where } S \simeq \pi \kappa a^2$$

$$\mathcal{L}/\mathcal{R} = \frac{\mu_0}{2\pi\eta} (S \cdot \ell) = C(\eta^{-1}) S \ell$$

- From the Wesley dataset, $C_{\min} \sim 1$ [see right]
- Note that C-Mod does not fit the scaling:
 - Higher current density leads to ohmic reheating during the CQ [Granetz 1996]
- Assuming $\ell_i = 0.5$, the ‘Wesley time’ is given by:

$$\tau_{CQ}(R, a, \kappa, \eta) = C(\eta^{-1}) \cdot S(a, \kappa) \cdot \ell(R, a)$$

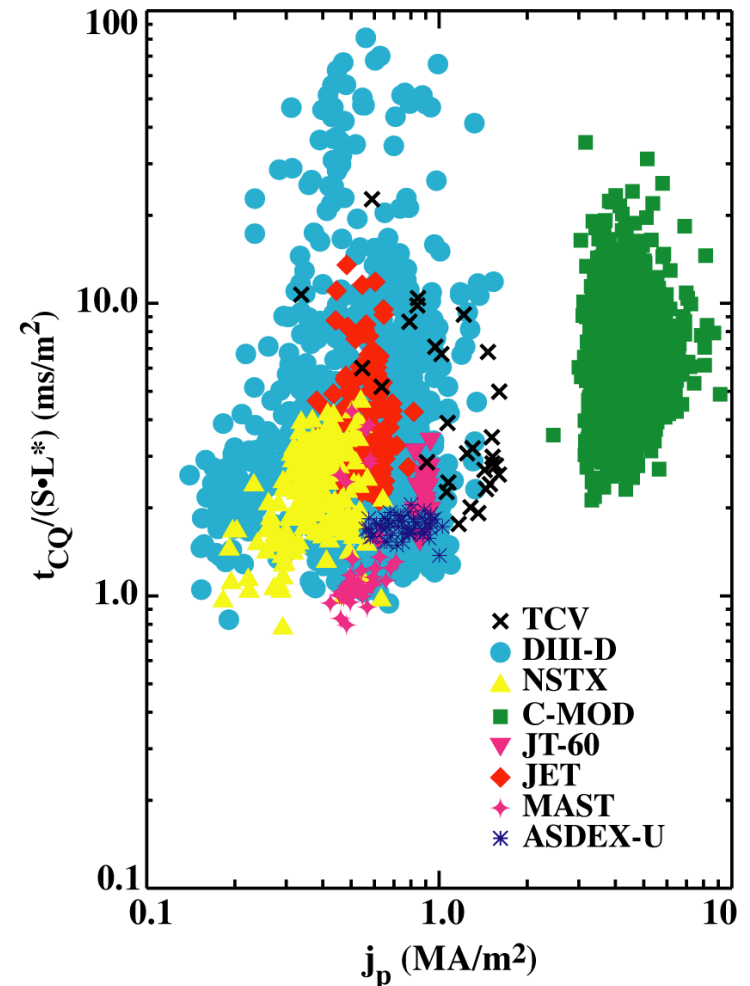

Wesley et al., IAEA FEC 2006, IT/P1-21

Comparison to the Wesley $\tau_{CQ} \sim L/R$ scaling

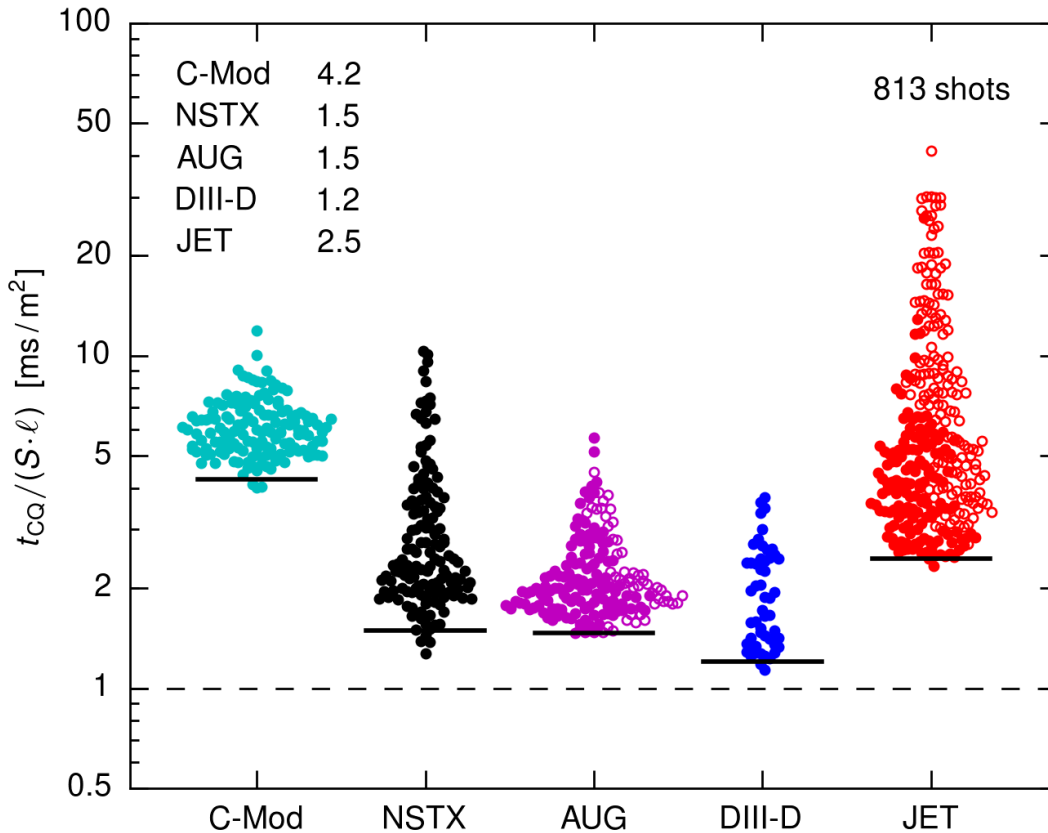

- Use R , a , and S values from EFIT to normalize
- Range of normalizations: $C = 1.2\text{--}4.2 \text{ ms}/\text{m}^2$
- C-Mod has the largest normalization, as expected
- Assume that ITER will lie in the $1.2\text{--}4.2 \text{ ms}/\text{m}^2$ range:
 $\rightarrow \tau_{CQ} \sim 37\text{--}130 \text{ ms}$

Analysis procedure: halo current rotation

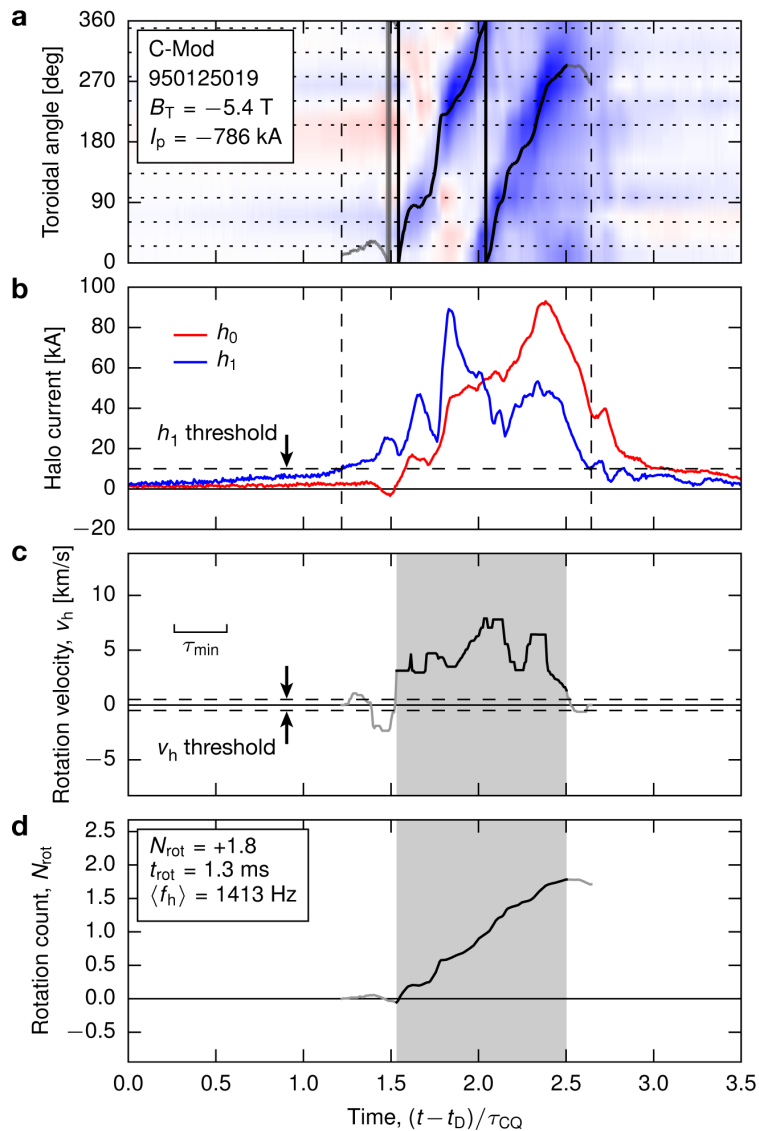

- Fit $n=0,1$ profile to each toroidal array at each time point:

$$I_h(\phi) = h_0 + h_1 \sin(\phi - h_2)$$

- Identify ‘asymmetry interval’ using $h_1 > 10$ kA threshold
- Identify ‘rotation interval’ using $|v_h| > 0.5$ km/s threshold
- Enforce minimum dwell time, $\tau_{\min} > 0.3 \tau_{\text{CQ}}$
- Record $N_{\text{rot}}, t_{\text{rot}}, \langle f_h \rangle = N_{\text{rot}} / t_{\text{rot}}$

Account for rotation locking or reversal

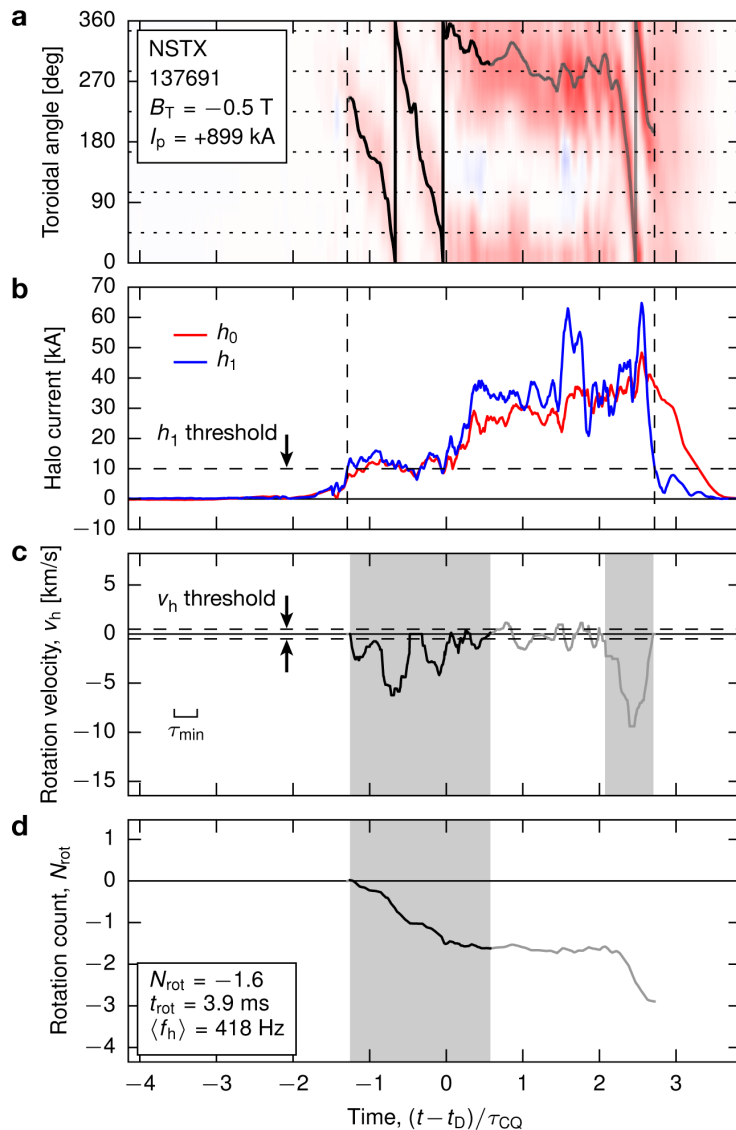

- Fit $n=0,1$ profile to each toroidal array at each time point:

$$I_h(\phi) = h_0 + h_1 \sin(\phi - h_2)$$

- Identify ‘asymmetry interval’ using $h_1 > 10$ kA threshold
- Identify ‘rotation interval’ using $|v_h| > 0.5$ km/s threshold
- Enforce minimum dwell time, $\tau_{min} > 0.3 \tau_{CQ}$
- Record N_{rot} , t_{rot} , $\langle f_h \rangle = N_{rot} / t_{rot}$
- In cases with multiple rotation intervals, select the longest (focus on low frequency cases)

Rotating halo current examples from each machine

C-Mod

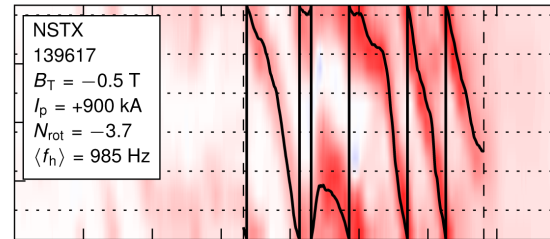
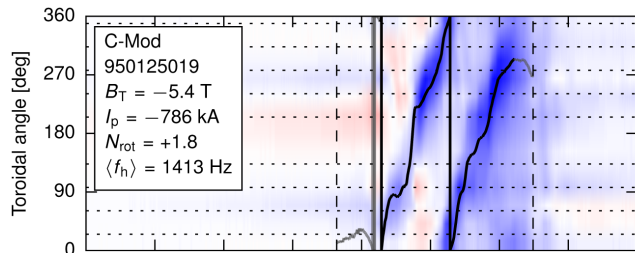

NSTX

AUG-C

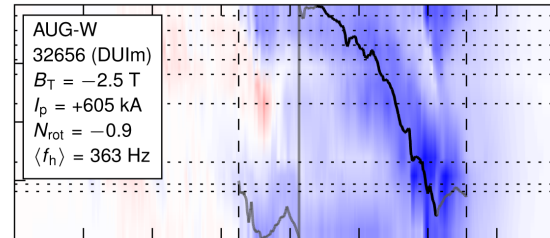
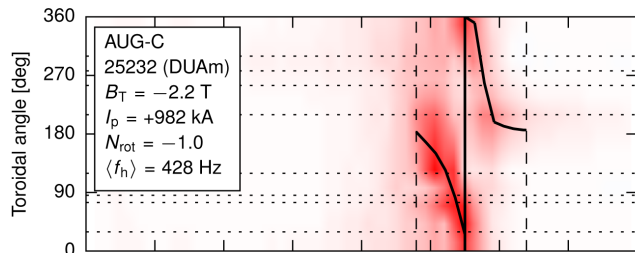

AUG-W

DIII-D

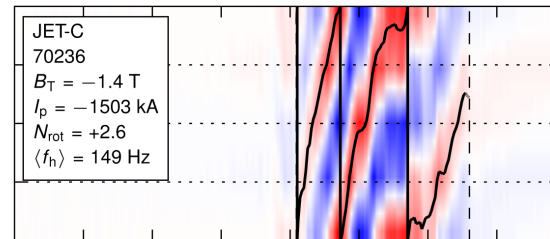
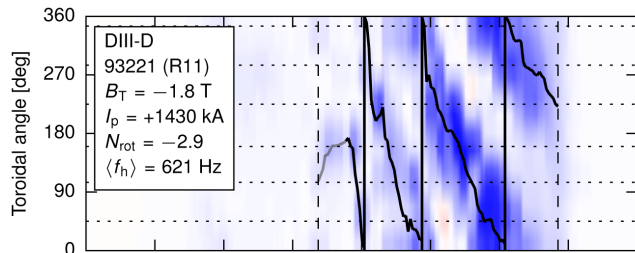

JET-C

JET-ILW

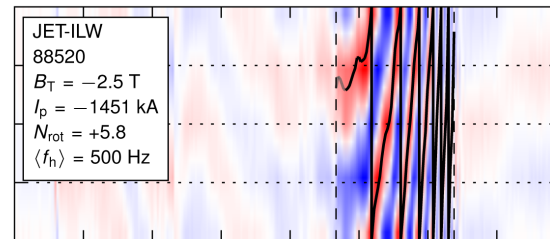
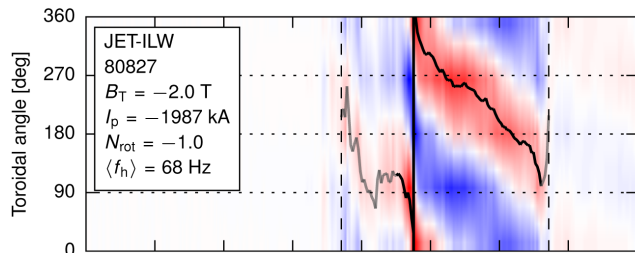

JET-ILW

The rotation is predominantly counter- I_p

- Many discharges with low rotation dither incoherently
- All discharges with $|N_{\text{rot}}| > 2$ rotate counter- I_p
- This effect is independent of the polarity of B_T
 - There are reversed B_T points from both DIII-D and C-Mod in the database
- The worst JET-ILW cases are no worse than the worst JET-C cases

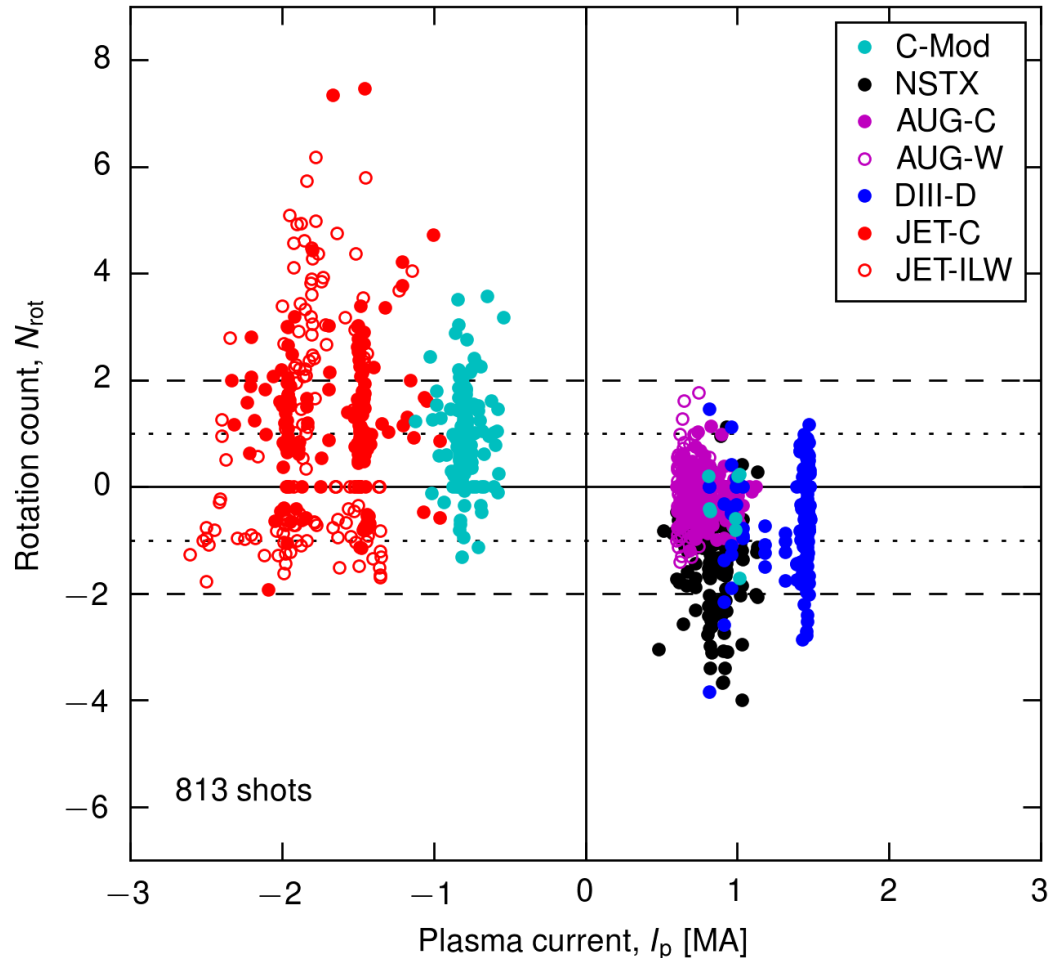

The rotation duration, t_{rot} , correlates with τ_{CQ} not t_{CQ}

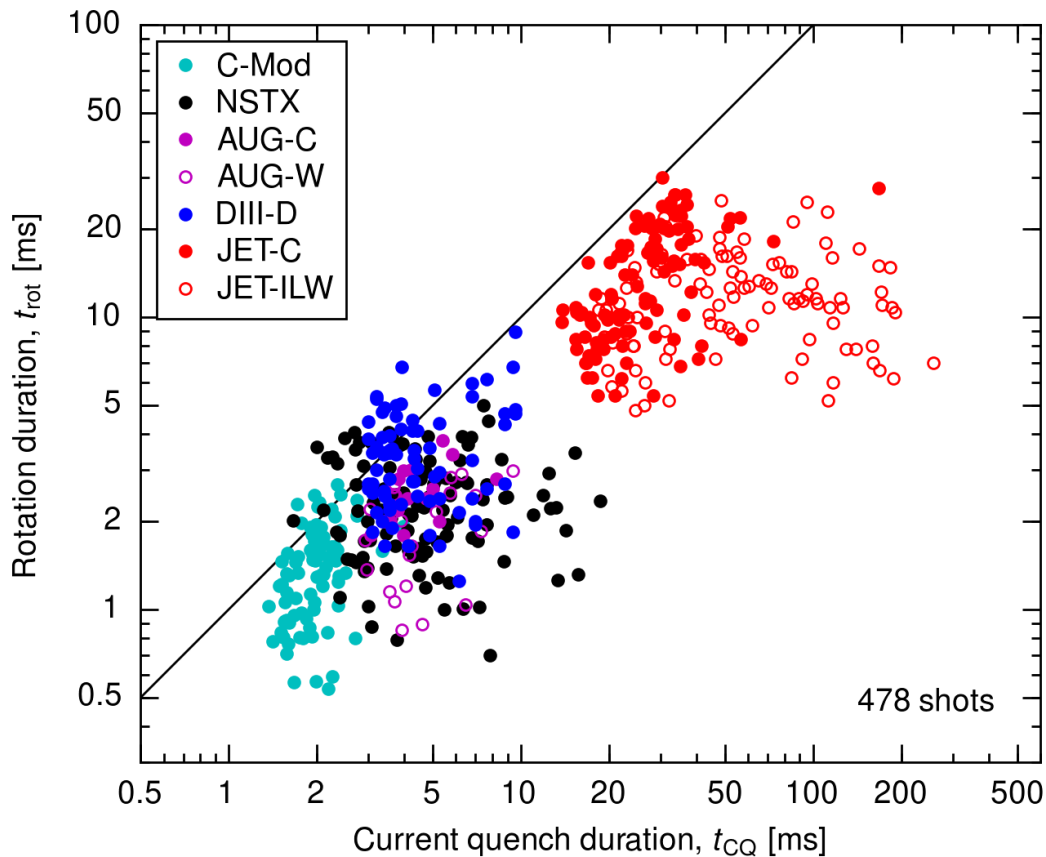

- Down-select to include only shots with $|N_{\text{rot}}| > 0.75$
- One might expect that t_{rot} scales with shot-specific t_{CQ}
- Instead, t_{rot} scales from device to device rather than shot-to-shot
- The minimum quench time, τ_{CQ} , captures the device-to-device scaling
- Use τ_{CQ} in t_{rot} regression

Empirical scaling of the rotation duration, t_{rot}

- Down-select to include only shots with $|N_{\text{rot}}| > 0.75$
- Carry out regression using one machine-specific parameter:
→ τ_{CQ}
- Additional parameters do not improve the regression:
→ $R, a, I_p, B_T, t_{\text{CQ}}$
- Hidden variables not available in the database may explain intra-machine variability

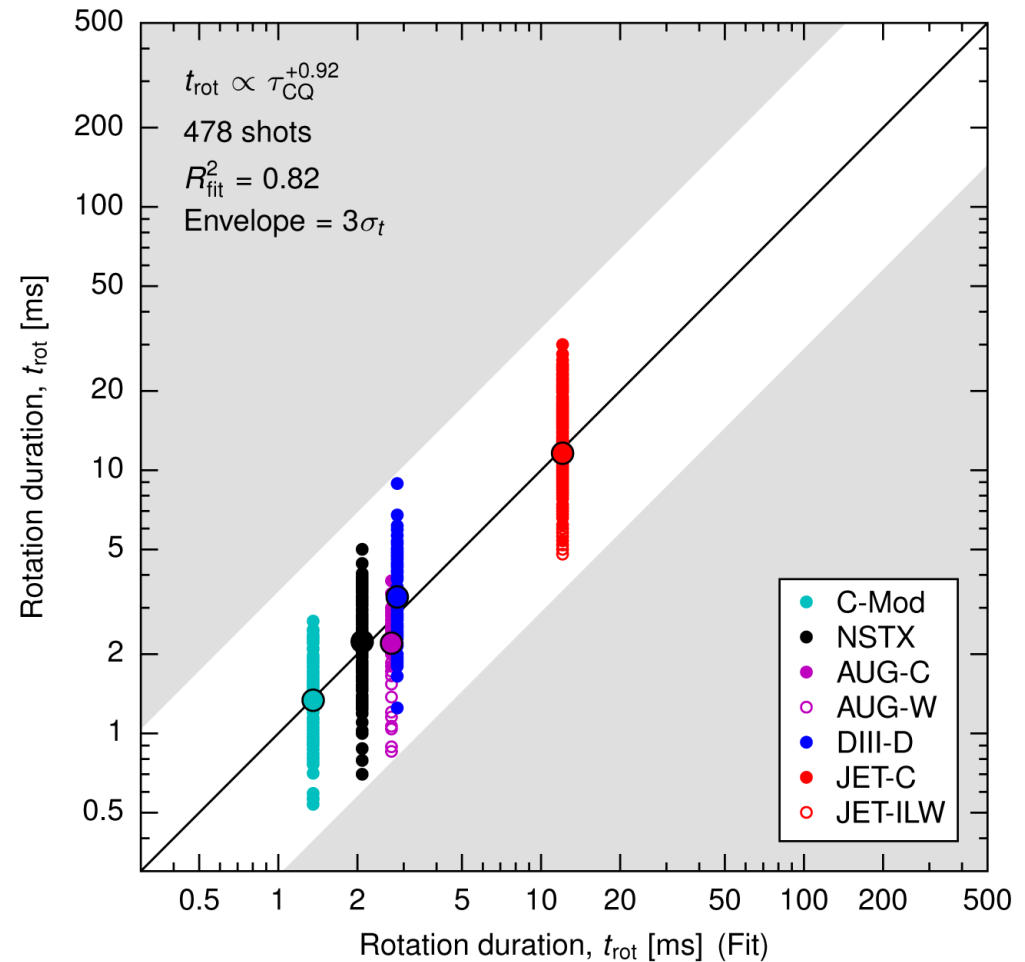

Project the rotation duration scaling to ITER

- Down-select to include only shots with $|N_{\text{rot}}| > 0.75$
- Carry out regression using one machine-specific parameter:
 - τ_{CQ}
- Additional parameters do not improve the regression:
 - $R, a, I_p, B_T, t_{\text{CQ}}$
- Hidden variables not available in the database may explain intra-machine variability
- Projecting to ITER gives upper bound of $t_{\text{rot}} = 105\text{--}330$ ms

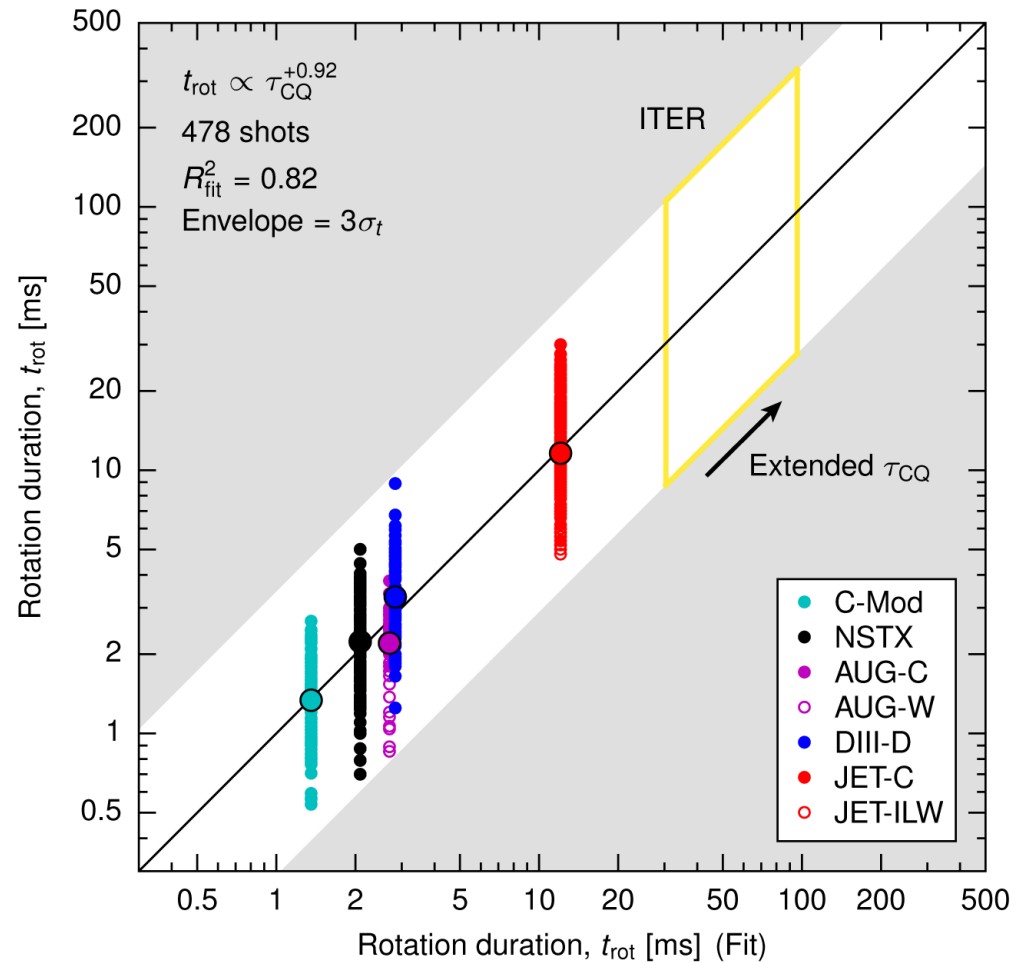

The normalized rotation duration is remarkably consistent

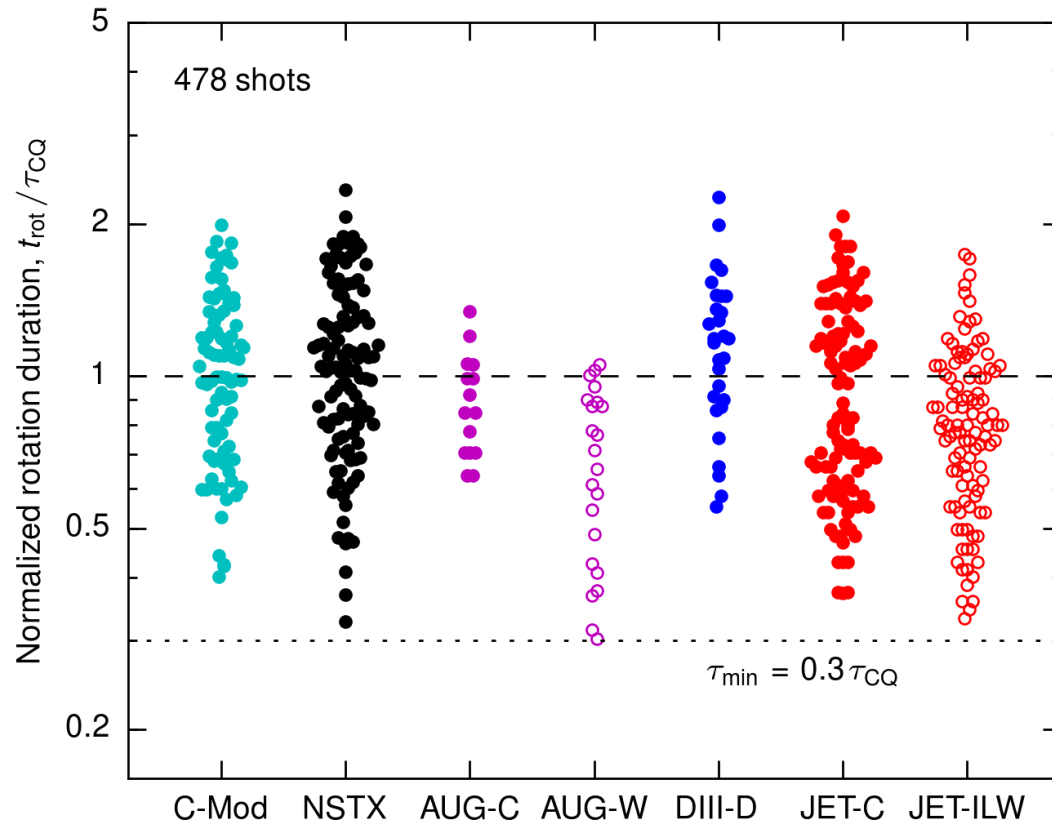

- As regression indicates, t_{rot} is roughly prop. to τ_{CQ}
- Most data points fall with a factor of two of τ_{CQ}
- Metal wall machines have comparable or even *shorter* rotation durations than their carbon counterparts
- Unable to determine what role the wall time might play since all wall times in the database are ~ 10 ms

Empirical scaling of the rotation frequency, $\langle f_h \rangle$

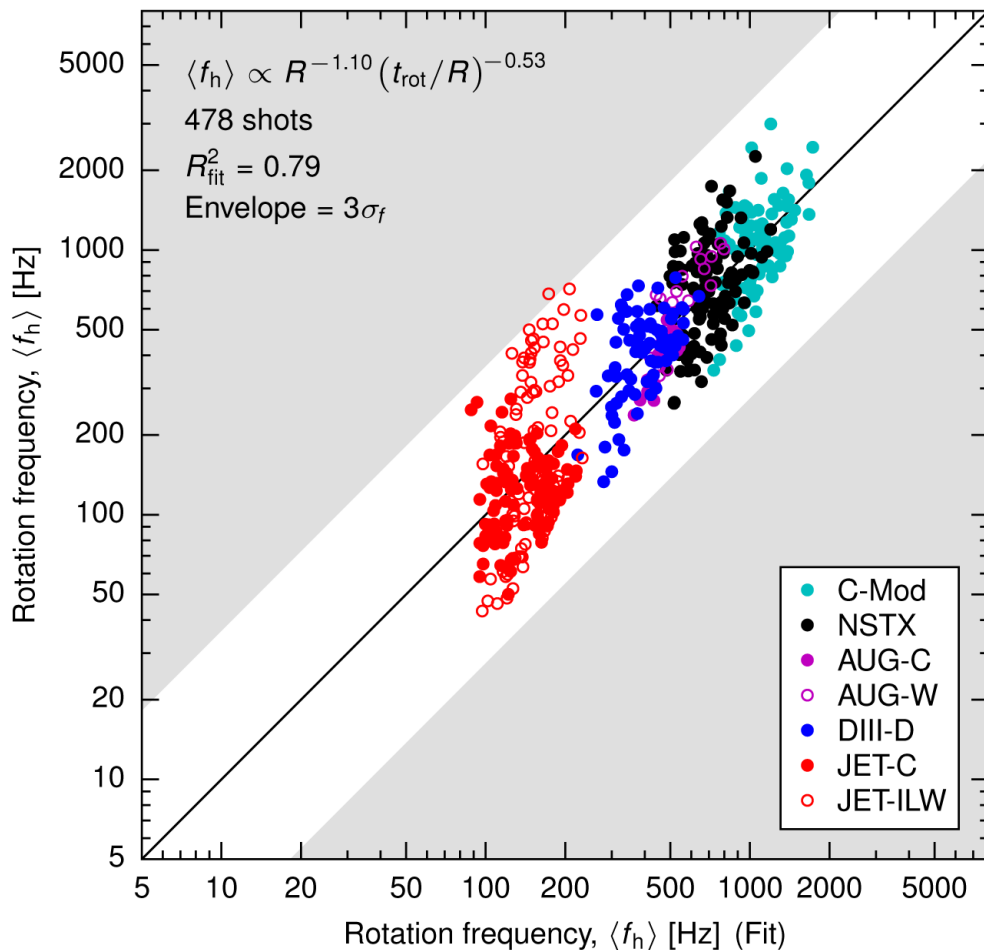

- Define the average rotation frequency as $\langle f_h \rangle = N_{\text{rot}} / t_{\text{rot}}$
- Carry out regression using two parameters:
 $\rightarrow R, t_{\text{rot}}$
- Additional parameters do not improve the regression:
 $\rightarrow a, I_p, B_T, t_{\text{CQ}}$
- Hidden variables not available in the database may explain intra-machine variability

Project the rotation frequency scaling to ITER

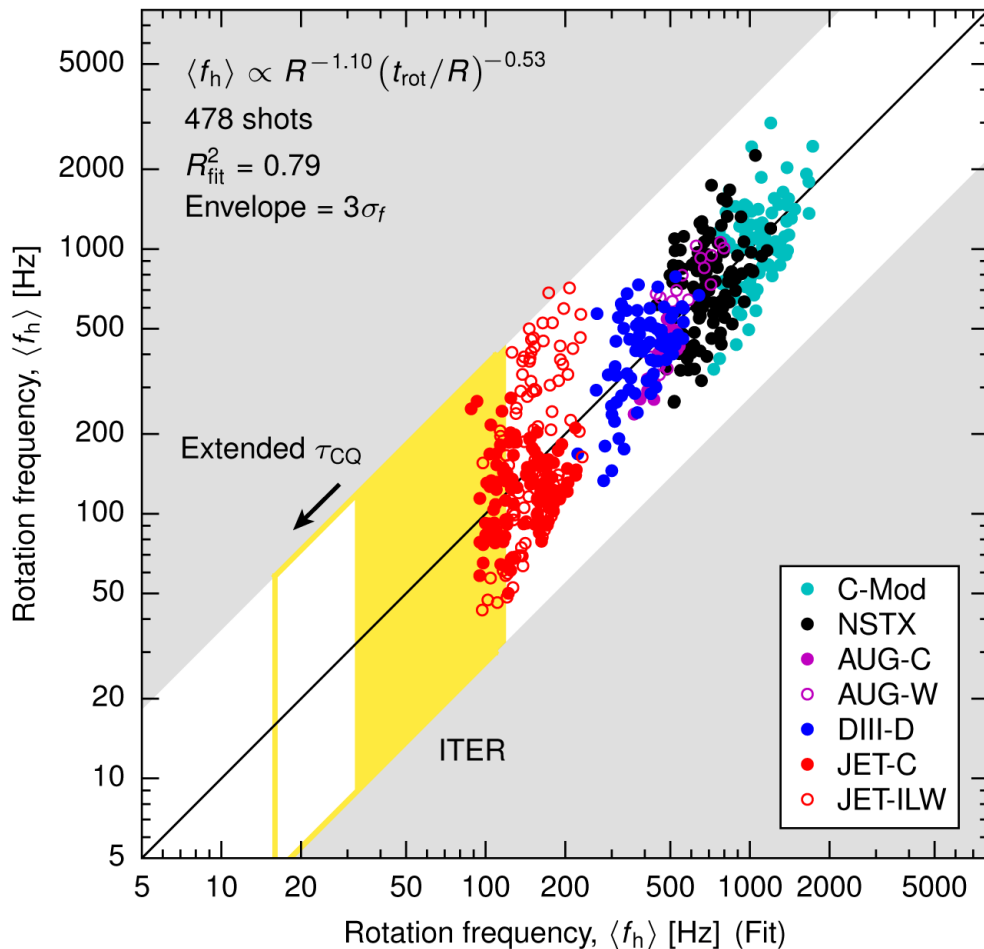

- Define the average rotation frequency as $\langle f_h \rangle = N_{\text{rot}} / t_{\text{rot}}$
- Carry out regression using two parameters:
 $\rightarrow R, t_{\text{rot}}$
- Additional parameters do not improve the regression:
 $\rightarrow a, I_p, B_T, t_{\text{CQ}}$
- Hidden variables not available in the database may explain intra-machine variability
- **Projecting to ITER indicates that halo current rotation below 20 Hz is probable**

The rotation velocity is also remarkably consistent

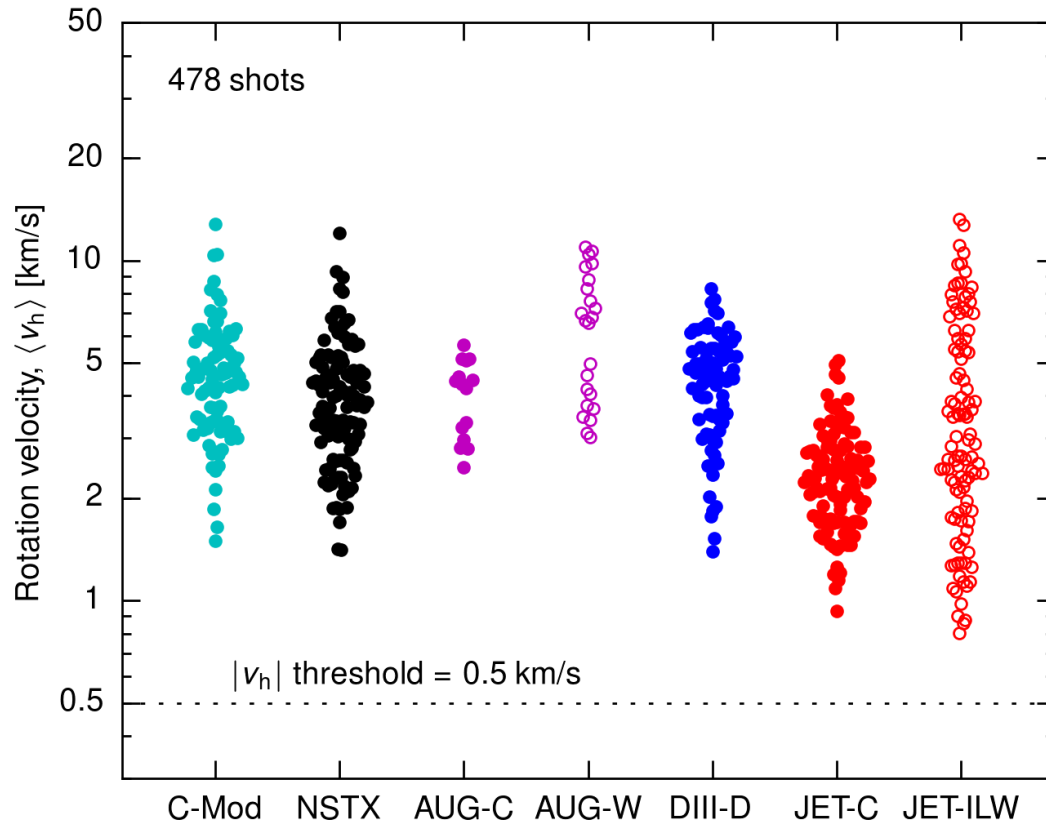

- As regression indicates, the rotation velocity should be relatively consistent
- All data points fall within a 0.7–17 km/s envelope
- Metal machines span the carbon space and add some faster points
- Any theory that explains halo current rotation must explain velocity invariance w.r.t. B_T , I_p , etc.

Projection to ITER → marginal w.r.t. damaging rotation

- ITER projections:
 - $N_{\text{rot}} > 3$ likely at $f_h > 20$ Hz
 - $N_{\text{rot}} \sim 3$ possible at $f_h \sim 20$ Hz
- Cannot rule out possibility of damaging rotation in ITER
- Scaling of τ_{CQ} is important

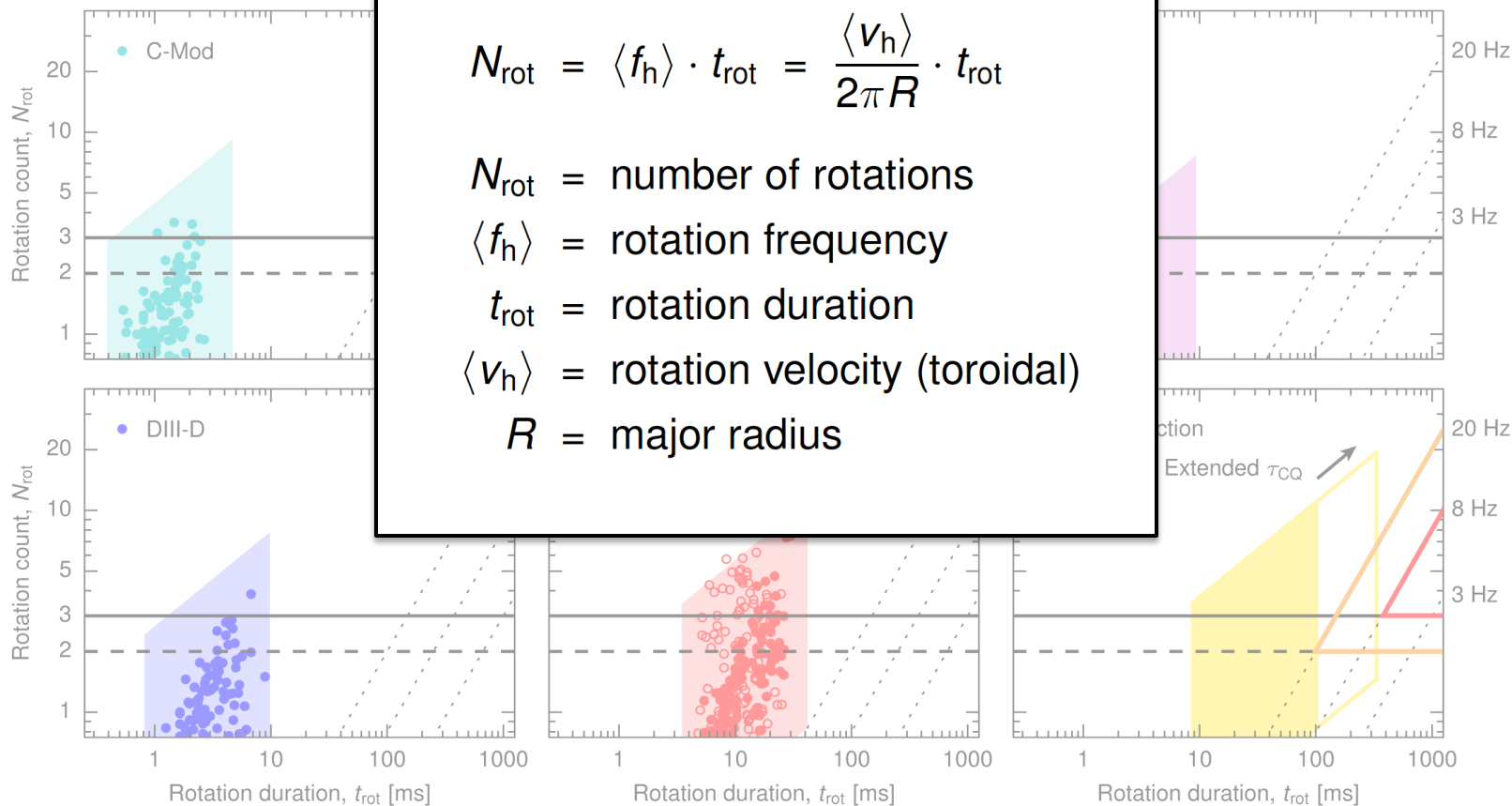

Projection to ITER → marginal w.r.t. damaging rotation

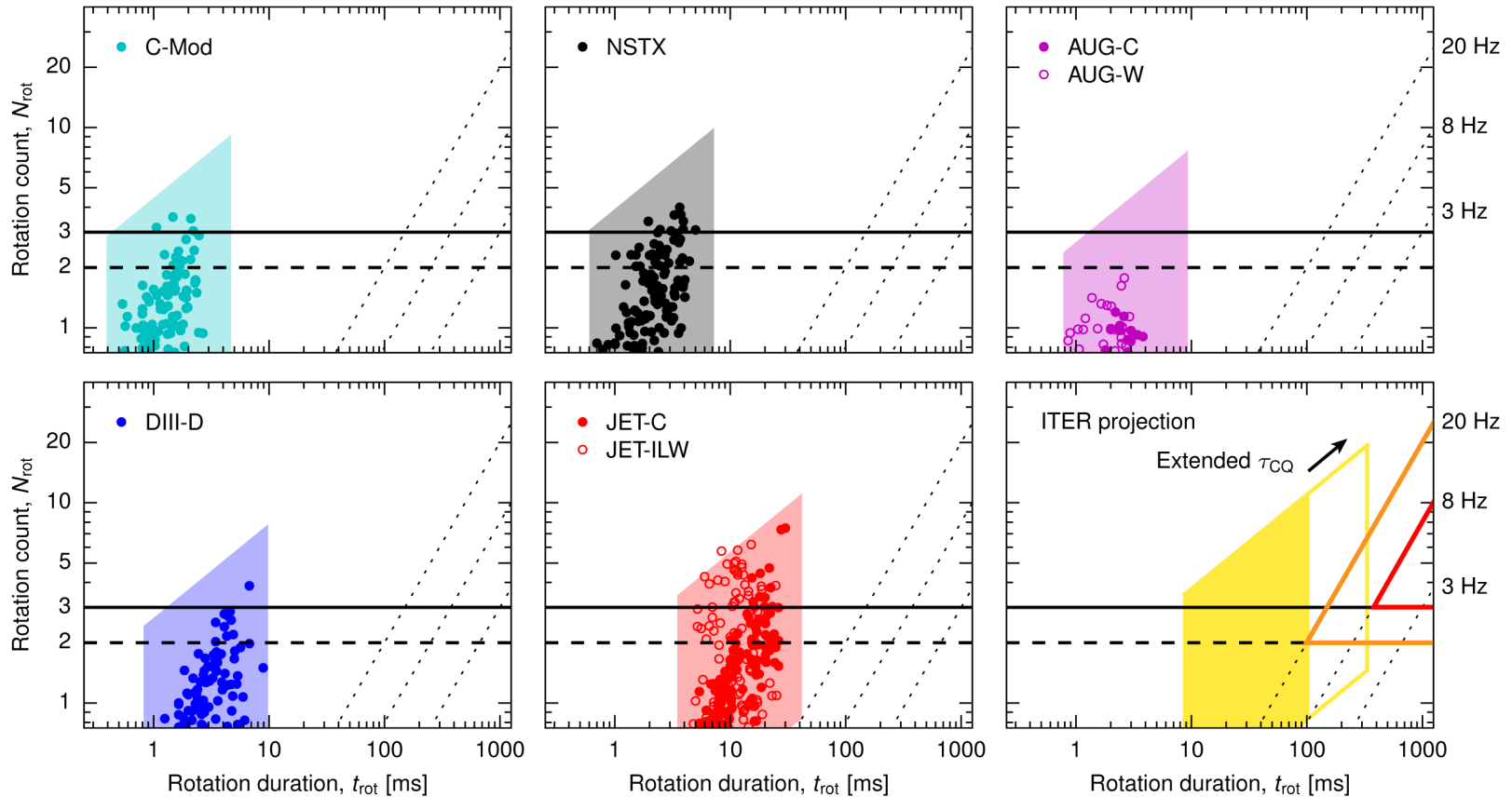

- ITER projections:
 - $N_{rot} > 3$ likely at $f_h > 20$ Hz
 - $N_{rot} \sim 3$ possible at f_h 9–20 Hz
- Cannot rule out possibility of damaging rotation in ITER
- Scaling of τ_{CQ} is important

Summary and future plans

- Empirical scalings for the rotation duration and frequency:
 - Duration scales with minimum current quench time
 - Frequency scales with major radius (to first order)
 - The rotation velocity changes very little from machine to machine
 - Requires physical mechanism independent of most parameters
- Projection to ITER:
 - $N_{\text{rot}} > 3$ likely above 20 Hz and possible down to 9 Hz
 - Therefore cannot rule out the possibility of resonant rotation in ITER
 - The scaling of τ_{CQ} to ITER is key
- Path forward:
 - Submitted to *Nuclear Fusion*, ITPA MDC WG-6 report
 - Theory → How to explain the various observed phenomena?
 - Preferentially counter- I_p rotation independent of B_T
 - Consistent rotation velocity